

B.O.M. SPARTAN CARBON

ITEMS	#SERVICE KIT	DESCRIPTION
1	KFC18003	BEARING KIT SPARTAN 2018+
2	KFC18011-01	PIVOT KIT SHAFT SPARTAN CARBON BLACK
3	KFC11051	DERAILLEUR HANGER SPLIT PIVOT 12x142/148
4	KFC18001-01	SPARTAN CARBON SHOCK BOLT BLACK
5	KFC18005	CABLE GUIDE KIT SPARTAN CARBON
6	KFC18007	CARBON SKIDPLATE/BOLT KIT SPARTAN
7	KFC18009	PROTECTOR KIT SPARTAN CARBON
8	KFC16053	FOAM KIT FOR INTERNAL ROUTING

SEATSTAY PIVOT

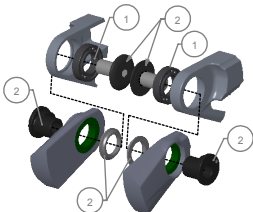

SHOCK HARDWARE

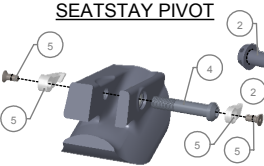

REAR AXLE

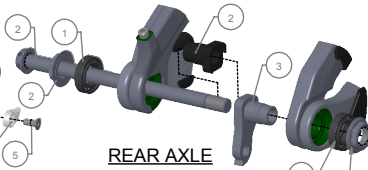

WARNING:
MAKE SURE TO CAREFULLY READ THE ASSEMBLY INSTRUCTIONS AND CLEANING INSTRUCTIONS NOTES ON NEXT PAGE.

PLAIN CABLE GUIDE, READ ASS. INSTRUCTION SECTION 7

LINKAGE PIVOT

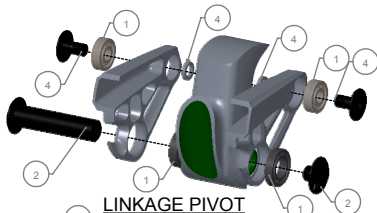

CHAINSTAY PIVOT

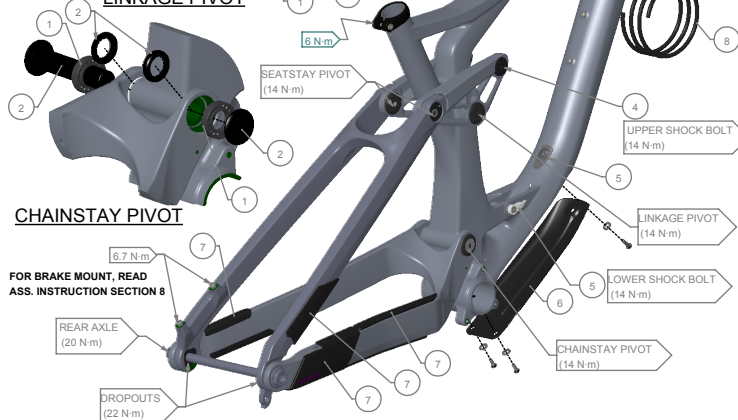

ASSEMBLY INSTRUCTIONS:

- 1- THOROUGHLY CLEAN THE INTERIOR OF EACH BEARING HOUSING TO REMOVE ANY DIRT OR OLD GREASE;
- 2- APPLY HIGH QUALITY WATERPROOF GREASE ON THE INSIDE FACE AND INSIDE DIAMETER OF ALL BEARING HOUSINGS BEFORE PRESS-FIT;
- 3- APPLY HIGH QUALITY WATERPROOF GREASE TO ALL PIVOT PARTS THAT CONTACT WITH THE INNER DIAMETER OF THE BEARINGS.
- 4- APPLY HIGH QUALITY WATERPROOF GREASE TO ALL NON-THREADED METAL-TO-METAL INTERFACES (EX.: PLANAR FACE OF THE PIVOT SPACER THAT CONTACTS THE LATERAL FACES OF THE FRONT TRIANGLE WL PIVOT). THESE INSTRUCTIONS ALSO APPLY TO THE SHOCK ASSEMBLY;
- 5- UNLESS OTHERWISE SPECIFIED, APPLY BLUE LOCTITE 242 ON ALL THREADS BEFORE ASSEMBLY TO THE SPECIFIED TORQUE VALUE;
- 6- TO PREVENT DAMAGE TO THE FRAME, THE SEATPOST MUST HAVE A MINIMUM INSERTION IN THE SEAT TUBE.

CARBON FRAME:

SMALL / MEDIUM - 70mm INSERTION
LARGE / X-LARGE - 100mm INSERTION

ALUMINIUM FRAME:

SMALL / MEDIUM / LARGE / X-LARGE - 100mm INSERTION

7- FRONT CABLE ENTRIES: IN ORDER TO BE COMPATIBLE WITH ALL CONFIGURATIONS, WE ADDED 2 PLAIN CABLE GUIDES (LEFT AND RIGHT) FOR THE FRONT ENTRY. THOSE CABLE GUIDE CAN BE DRILLED MANUALLY USING THE POSTION MARKS ON THE BACK.

8- REAR BREAK MOUNT: DURING THE ASSEMBLY, YOU WILL NOTICE THAT THE NATURAL BEND OF THE BRAKE CABLE MAY COME IN CONTACT WITH THE WHEEL'S SPOKES OR THE FRAME. SO WE HIGHLY SUGGEST TO GIVE A FULL ROTATION OF THE BRAKE BEFORE MOUNTING IT. IT WILL GIVE A TWIST TO THE CABLE AND PREVENT POTENTIAL CONTACTS.

9- FRG ADJUSTABLE: THIS DESIGN ALLOWS RIDERS TO CHOOSE BETWEEN A LOW OR HIGH POSITION. WITH FRG ADJUSTABLE TECHNOLOGY, YOU CAN FINE-TUNE YOUR RIDE TO PERSONAL TASTES OR SPECIFIC TRAIL TYPES USING A FLIP-FLOP PIVOT MECHANISM THAT SLIGHTLY CHANGES THE BIKE'S GEOMETRY AS SHOWN BELOW.

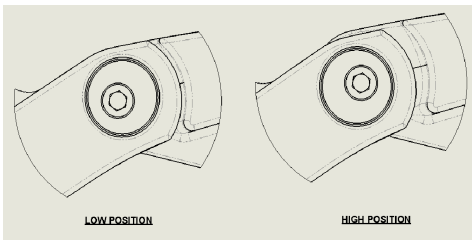

CLEANING INSTRUCTIONS:

IT IS A WELL KNOWN FACT THAT A CLEAN BIKE PERFORMS BETTER. DEVINCI RECOMMENDS WASHING YOUR BIKE REGULARLY USING A BRUSH AND SOAPY WATER. HOWEVER, DEVINCI DO NOT RECOMMEND THE USE OF A PRESSURE WASHER, SINCE THIS MAY SIGNIFICANTLY REDUCE THE SERVICE LIFE OF BALL BEARINGS. EVEN THOUGH OUR BALL BEARINGS ARE EQUIPPED WITH HIGH QUALITY DOUBLE-LIP SEALS, HIGH PRESSURE WATER CAN STILL PASS THESE SEALS AND REMOVE THE GREASE INSIDE THE BEARING. THIS MAY CAUSE PREMATURE CORROSION AND WEAR OF THE BALL BEARINGS.

- Câble de tige de selle
- Câble du dérailleur arrière
- Câble du frein arrière
- Câble à l'extérieur du cadre
- Câble à l'intérieur du cadre

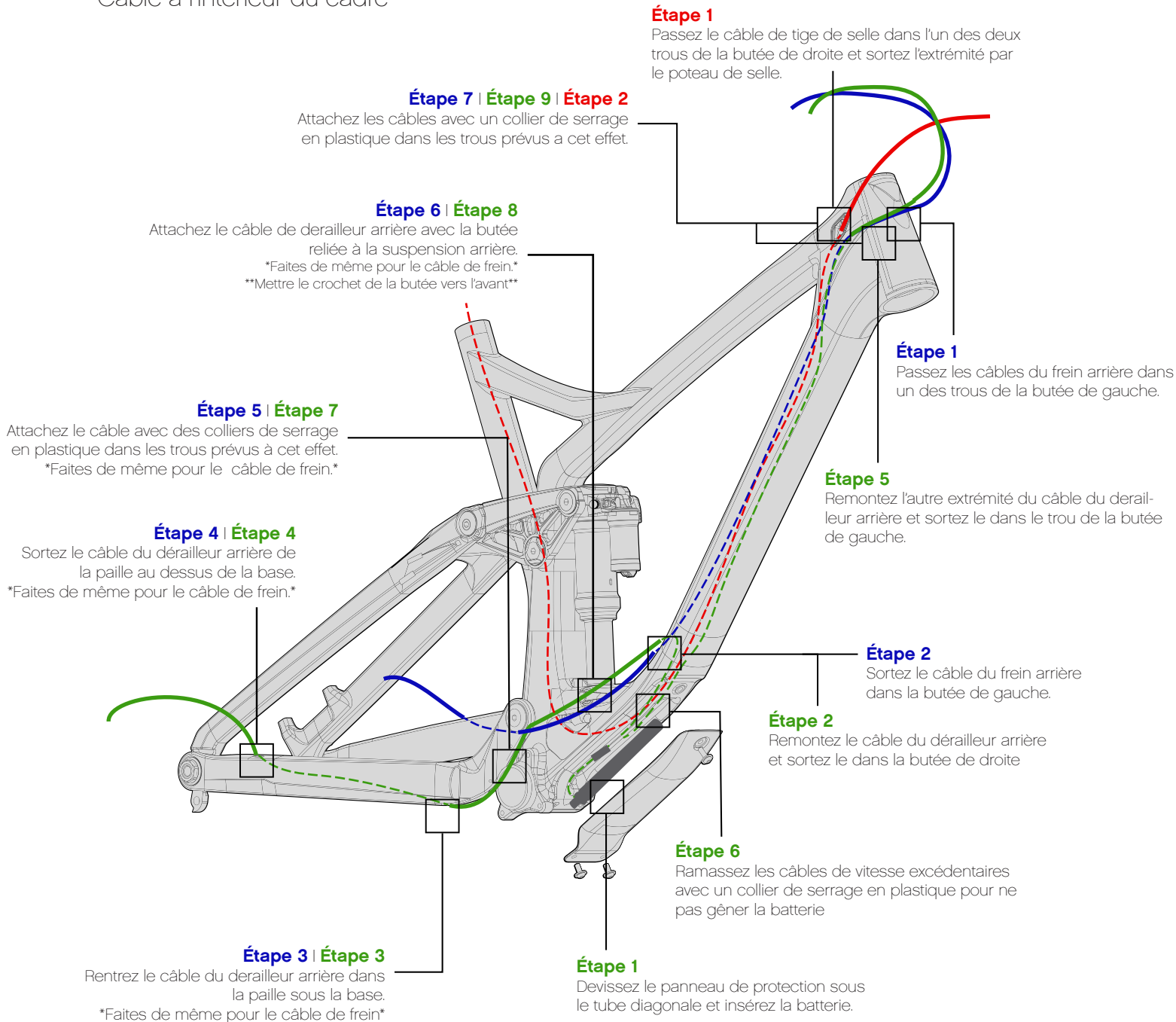

DEVINCI

TRANSMISSION À CÂBLE ET TIGE DE SELLE

- Câble de tige de selle
- Câble du dérailleur arrière
- Câble du frein arrière
- Câble à l'extérieur du cadre
- Câble à l'intérieur du cadre

